

Standard Construction and Materials

FRAME: .081" thk. (nominal) extruded aluminum, 6063-T52/T6 alloy.

BLADE: .081" thk. (nominal) extruded aluminum, 6063-T52/T6 alloy.
Blades approximately 1 1/8" on centers.

LOUVER FACE: Blades are contained within jambs, sill contains jambs, and head is flush with jambs.

SCREENS: (When indicated, in a removable frame.)

1/2" flattened aluminum (.051" thick),

-or- 1/2" sq. mesh, intermediate double-crimped aluminum wire, .063" dia.,

-or- 18/16 mesh, .011" dia. aluminum wire, insect screen.

DRAIN SILL PAN: .060" thick (nominal) formed aluminum.

FINISH: Mill

Options

Finish - Baked Enamel, Kynar, Anodize

Notes

1. Nominal deductions will be made to the opening size given.
2. Approximate shipping weight is 5.5 lbs./sq.ft.

Louver Sizes

Min Panel	Max Single Panel
12"W x 12"H	60"W x 96"H

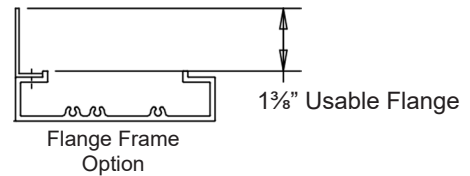
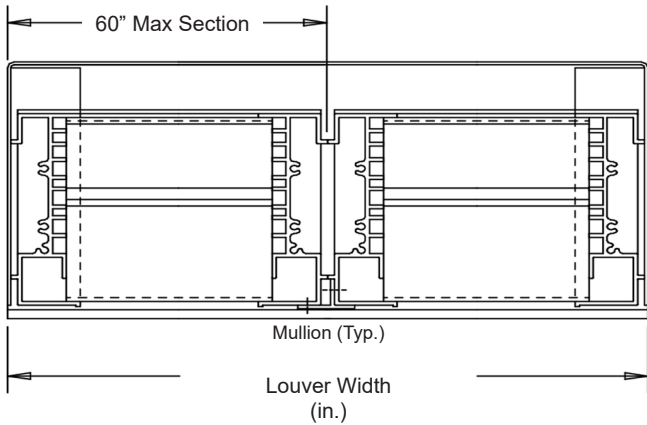
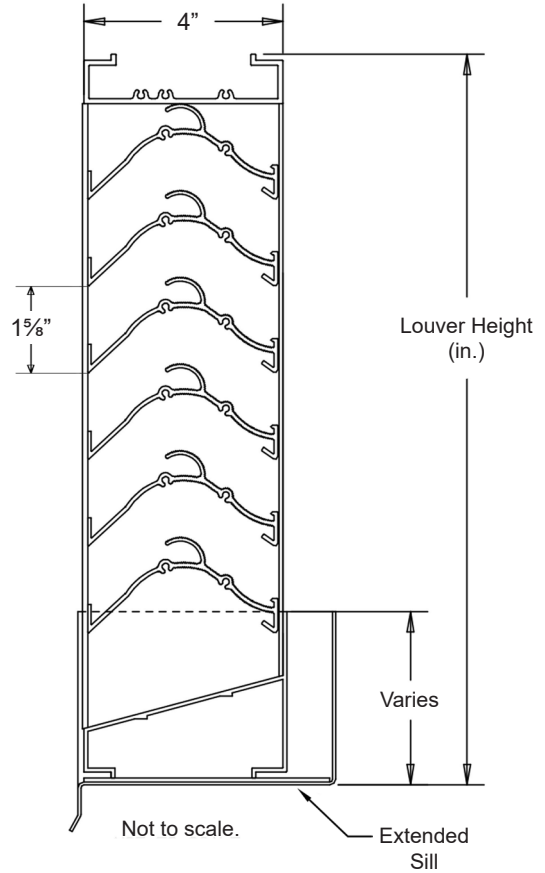

											 Union Made
Item #	Qty	Width	Height	Width	Height	Mullion	Type	Location			
		Opening Size		Louver Size			Screens				
Arch. / Eng.:						EDR:		ECN:		Job:	
Contractor:											
Project:						Date:		DWN:		DWG:	

In the interest of product development, Cesco Products reserves the right to make changes without notice.



450 Riverside Dr • Wyalusing PA, 18853
Phone: 570-746-1888 • Fax: 570-746-9286
www.cescoproducts.com

Performance Data

Pressure Drop: .260 in. w.g. at 1000 fpm (intake)

Free Area: 7.50 sq.ft. = 47% for 48"W x 48"H sample tested in accordance with AMCA Standard 500-L.

Class "A" Rating with 99% efficiency at 3 in. rain fall at intake velocity of 1302 fpm (7,174 cfm) at wind speed of 29 mph.

Class "B" Rating with 95.8% efficiency at 8 in. rain fall at intake velocity of 1102 fpm (6,071 cfm) at wind speed of 50 mph.

Testing based on 48" x 48" based on AMCA Standard 500-L.

Ratings do not include effects of a screen.

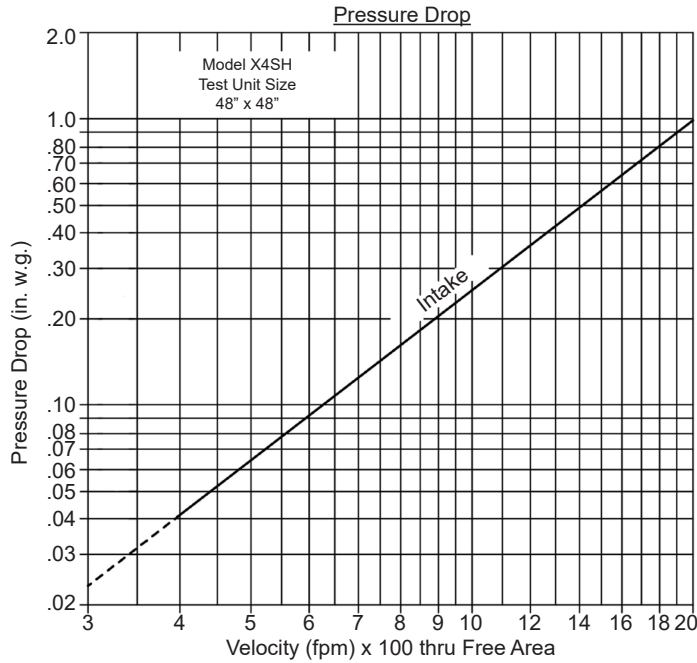

Intake air converted to standard air density.
Tested to AMCA Standard 500-L, Figure 5.5.

Free Area (sq. ft.)

		Width (in.)								
		12"	18"	24"	30"	36"	42"	48"	54"	60"
Height (in.)	12"	.20	.33	.46	.59	.72	.85	.98	1.11	1.24
	24"	.73	1.19	1.66	2.12	2.59	3.05	3.52	3.98	4.45
	36"	1.19	1.94	2.70	3.46	4.22	4.98	5.74	6.50	7.26
	48"	1.71	2.80	3.90	4.99	6.09	7.18	7.50	9.37	10.46
	60"	2.17	3.56	4.95	6.33	7.72	9.11	10.50	11.89	13.27
	72"	2.63	4.31	5.99	7.67	9.36	11.04	12.72	14.40	16.08
	84"	3.15	5.17	7.19	9.21	11.22	13.24	15.26	17.27	19.29
	96"	3.61	5.92	8.23	10.55	12.86	15.17	17.48	19.79	22.10

■ Wind Driven Rain

Wind Driven Rainwater Penetration Test

Conducted to AMCA Standard 500-L.

Test size 1m x 1m (39.7" x 39.7") core area, nominal.

Louver Free Area 5.51 square feet.

Core Ventilation (m/s)	0.0	0.5	1.0	1.5	2.0	2.5	3.0	3.5	Rain Fall / MPH 3 in. / hr. rain fall and 29 mph Velocity
FPM	0	98	197	295	394	492	578	666	
Free Area Ventilation (cfm)	-	-	-	-	-	5,302	6,220	7,174	
Free Area Velocity (fpm)	-	-	-	-	-	962	1,129	1,302	
Effective Rating Class	A	A	A	A	A	A	A	A	8 in. / hr. rain fall and 50 mph Velocity
FPM	0	102	198	282	381	468	564	690	
Free Area Ventilation (cfm)	0	1,100	2,129	3,041	4,105	5,041	6,071	7,433	
Free Area Velocity (fpm)	0	200	386	552	745	915	1,102	1,349	
Effective Rating Class	B	B	B	B	B	B	B	C	

Wind Driven Rain Penetration Classifications

Class	Effectiveness %
A	100 to 99%
B	98.9% to 95%
C	94.9% to 80%
D	Below 80%

Discharge Loss Coefficient Classifications

Class	Discharge Loss Coefficient
1	0.4 and above
2	0.3 to 0.399
3	0.2 to 0.299
4	0.199 and below

Discharge Coefficient
Intake Cd= 0.25 (Class 3)

Class 1 Loss Coefficient has the least resistance to airflow.

1. Core area is the front opening of a louver assembly with the blades removed.
2. Core area velocity is the airflow rate through the louver divided by the core area (39.37" x 39.37").
3. Free area is the minimum area through which air can pass. It is determined by multiplying the sum of the minimum distance between intermediate blades, top blade and head, bottom blade and sill, by the minimum distance between jambs.
4. Discharge loss coefficient is calculated by dividing a louver actual airflow rate vs. a theoretical airflow for the opening, providing an indication of the louver air flow characteristics.



Cesco Products certifies that the Model X4SH shown herein is licensed to bear the AMCA seal. The ratings shown are based on tests and procedures performed in accordance with AMCA Publication 511 and comply with the requirements of the AMCA Certified Ratings Program. The AMCA Certified Ratings Seal applies to Air Performance and Wind Driven Rain Ratings only.